

Technical Manual

K2 S9800/K2 S9800SE



ACOUSTIC & ELECTRICAL SPECIFICATIONS:

- Nominal Impedance 8Ω
- Max Amp Power 400 watts*
- Frequency Response 45Hz – 50kHz (–6dB)
- Sensitivity 94dB (2.83 volts @ 1 meter)
- Crossover Frequencies 800Hz, 10kHz

SYSTEM COMPONENTS:

- Cabinet K2S9800/K2S9800SE (not for sale)
- Grille 337854-001
- Ultrahigh Frequency Transducer 1" (25.4mm) 045Be Beryllium (336318-001)
DC Resistance 3.1 ohms ±3%
- High-Frequency Transducer 3" (76.2mm) 435Be Beryllium (337361-001)
DC Resistance 3.6 ohms ±10%
- Low-Frequency Transducer 15" (381mm) 1500AL Alnico (336308-001)
DC Resistance 5.3 ohms ±10%
- Crossover Network 337978-001

AURAL SWEEP TEST SPECIFICATIONS:

- System Aural Sweep Test 6.0V input 40Hz to 50kHz
- L.F. Aural Sweep Test 20.0V input 20Hz to 600Hz
- H.F. Aural Sweep Test 2.0V input 500Hz to 10kHz
- U.H.F. Aural Sweep Test 1.00V input 7kHz to 50kHz

PHYSICAL SPECIFICATIONS:

- Enclosure Dimensions 51" x 20" x 14-3/4" (H x W x D)
Plus spiked feet (1295mm x 508mm x 375mm)
- Weight 198 lb/90 kg (each)

WARRANTY:

- Refer to Warranty Statement packed with each product

* The maximum recommended amplifier power rating will ensure proper system headroom to allow for occasional peaks. We do not recommend sustained operation at these maximum power levels.

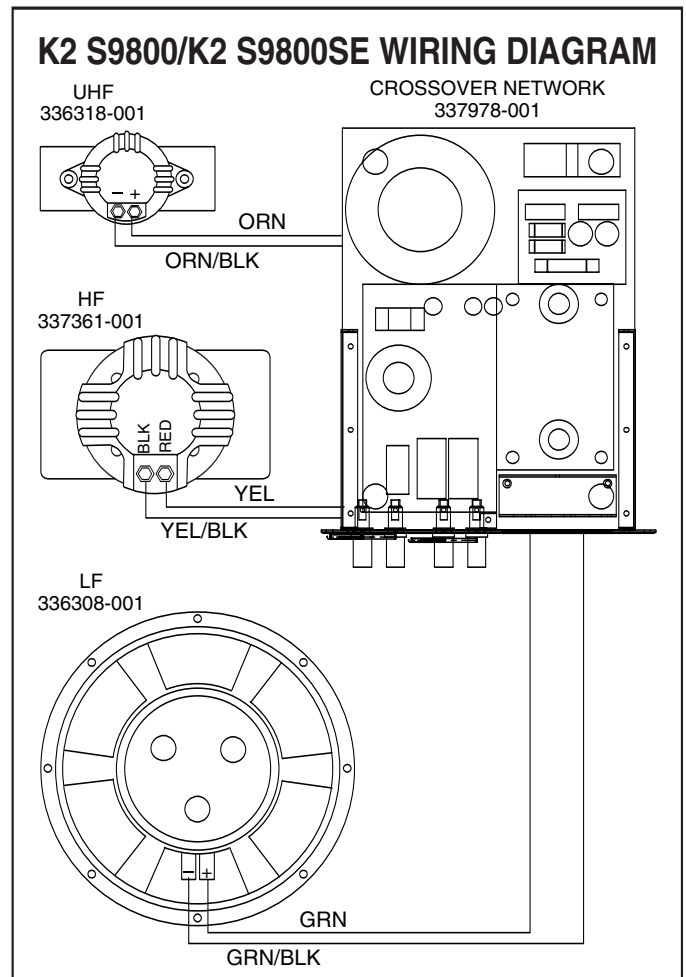
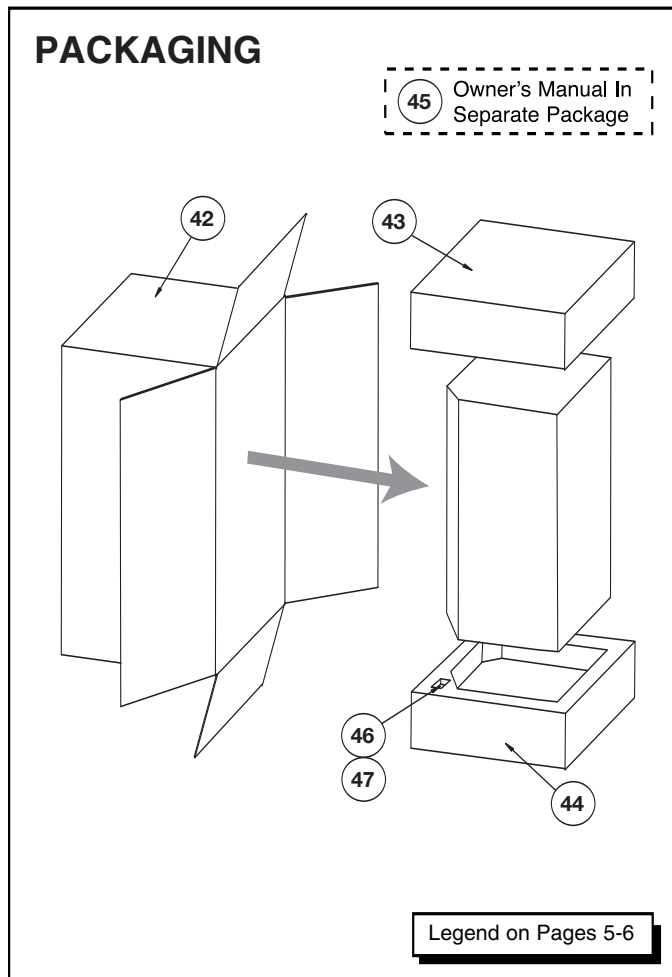



SCHEMATIC K2 S9800

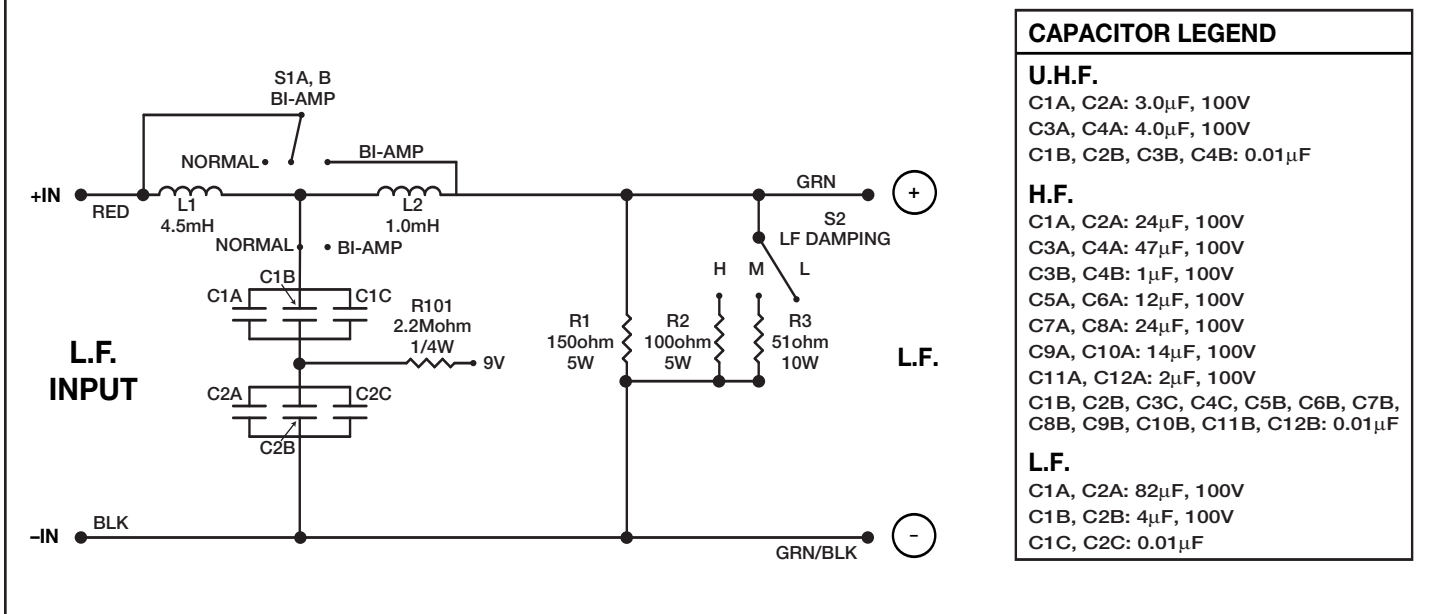
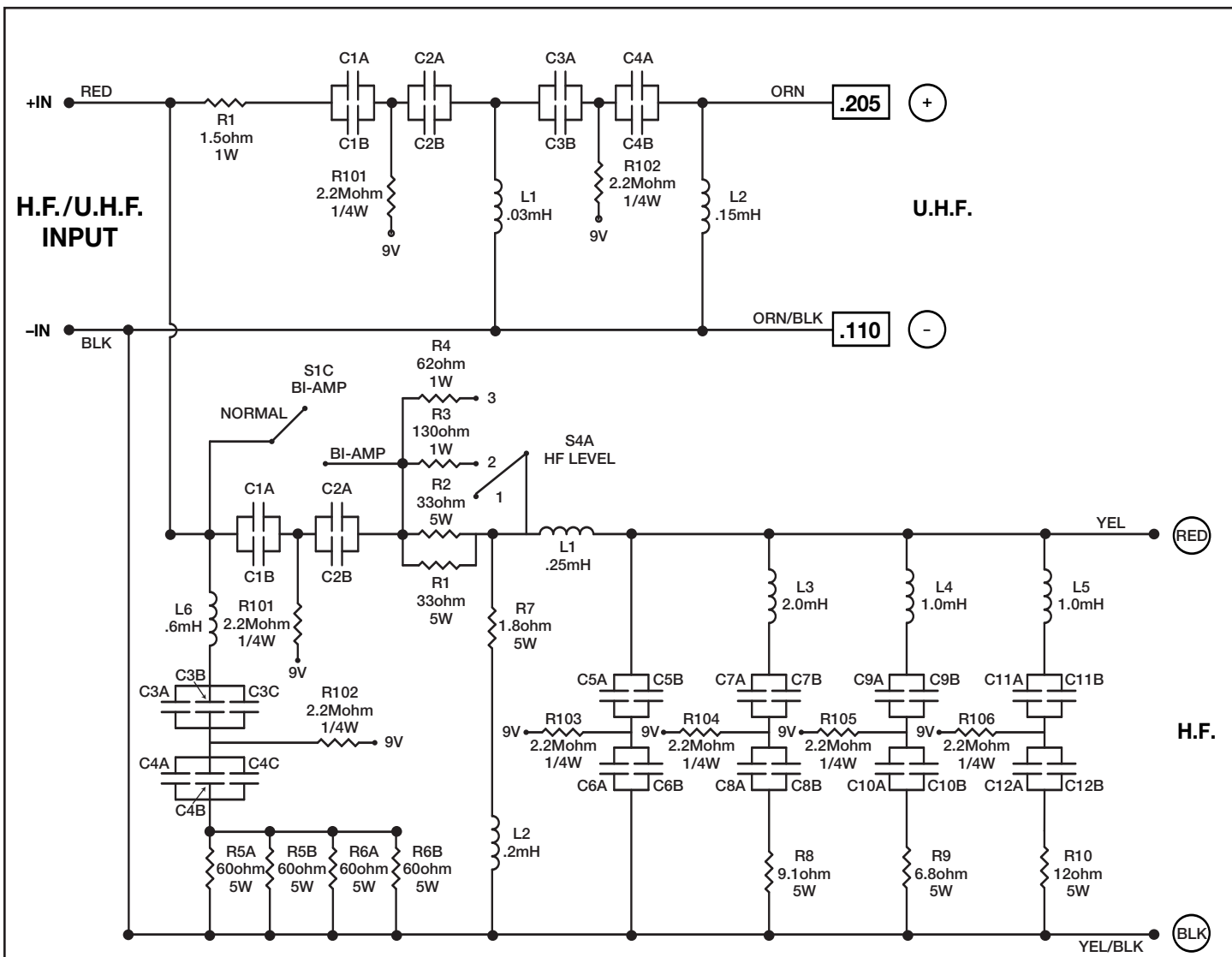

CAPACITOR LEGEND	
U.H.F.	
C1A, C2A:	3.0μF, 100V
C3A, C4A:	4.0μF, 100V
C1B, C2B, C3B, C4B:	0.01μF
H.F.	
C1A, C2A:	24μF, 100V
C3A, C4A:	47μF, 100V
C3B, C4B:	1μF, 100V
C5A, C6A:	12μF, 100V
C7A, C8A:	24μF, 100V
C9A, C10A:	14μF, 100V
C11A, C12A:	2μF, 100V
C1B, C2B, C3C, C4C, C5B, C6B, C7B, C8B, C9B, C10B, C11B, C12B:	0.01μF
L.F.	
C1A, C2A:	82μF, 100V
C1B, C2B:	4μF, 100V
C1C, C2C:	0.01μF

K2 S9800/K2 S9800SE



SCHEMATIC K2 S9800SE

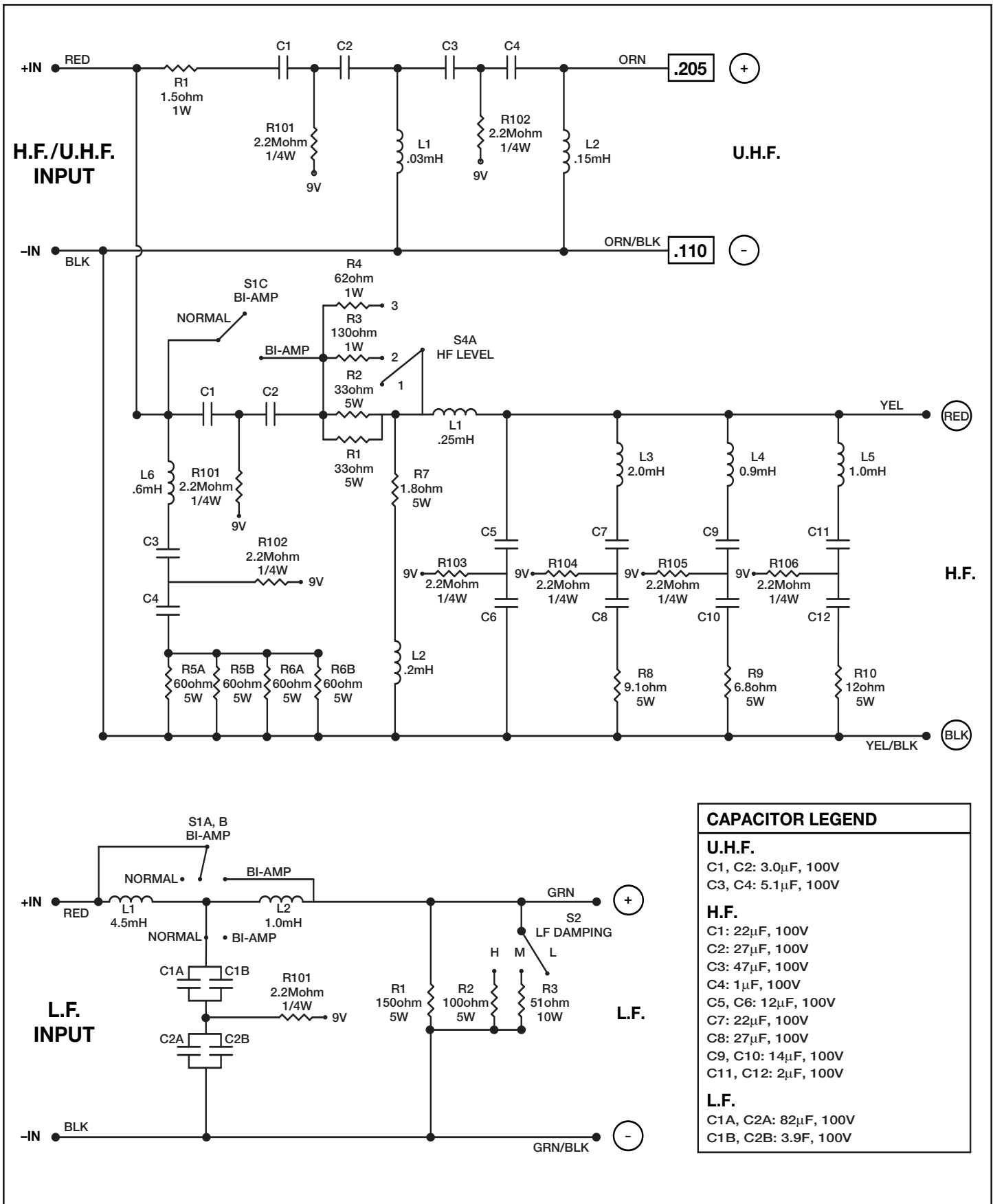

EXPLODED VIEW

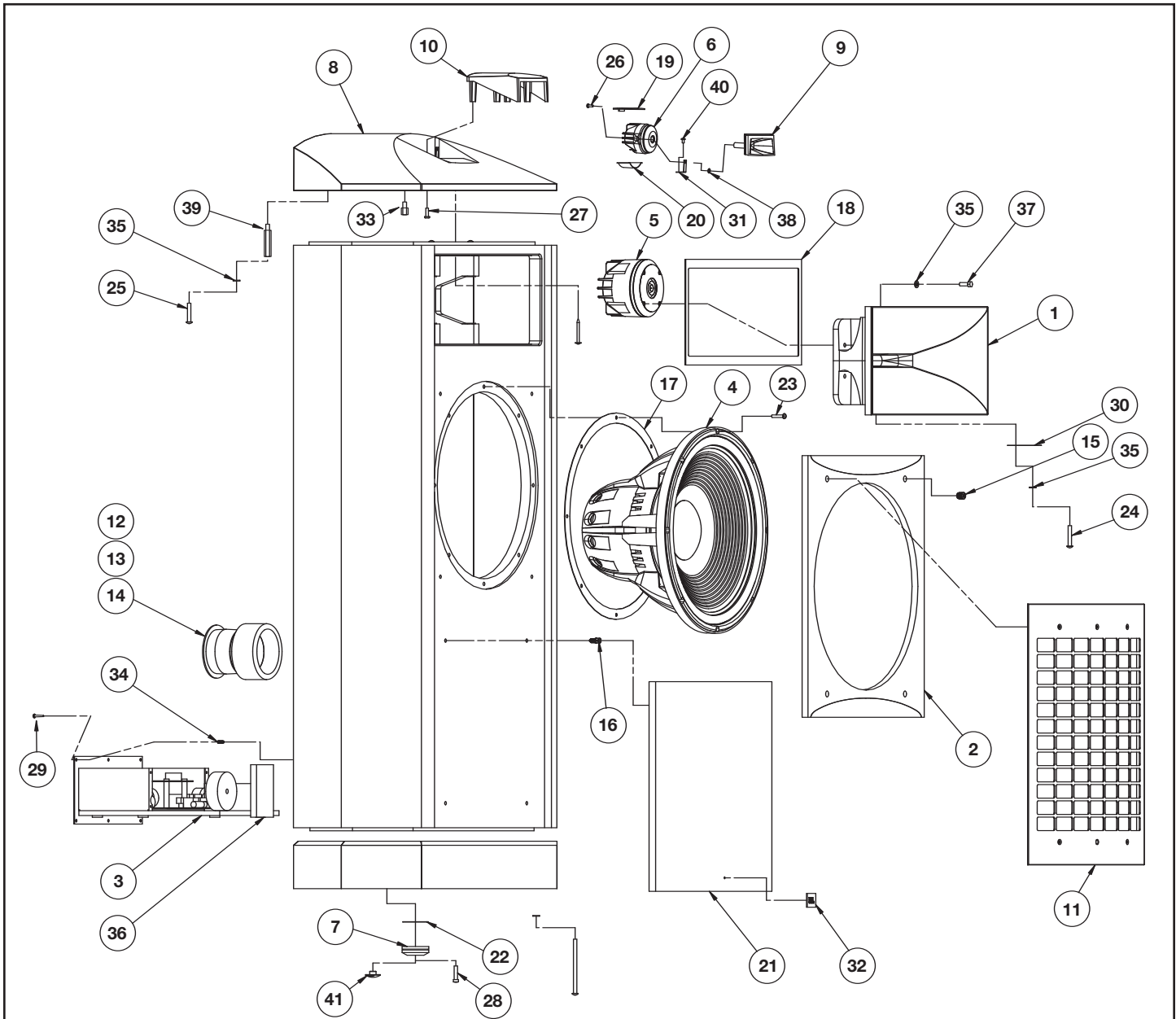

TO SERVICE THE K2 S9800

The crossover network, after removal of the (6) faceplate screws, should extract far enough out of the cabinet for service without wire or driver removal.

Access to 9V bias batteries – metal plate removed by two thumbscrews on the network faceplate.

Replacement or service of the high-frequency drivers requires access through the woofer opening, following these steps:

NOTE: IT IS RECOMMENDED TWO PERSONS BE INVOLVED IN K2S9800 DISASSEMBLY

- 1) Lay the loudspeaker down, on its back (drivers facing up), on a padded surface.
- 2) Remove the grille.
- 3) Remove the (8) Phillips woofer screws.
- 4) The woofer is best extracted by inserting two 1/4 x 20 (3" or longer) threaded machine screws into opposite sides of the two threaded woofer screw openings. Caution: Only two of the holes are threaded; they should be the top and bottom holes in the woofer frame. Thread

the bolts into the openings by hand, then pull upwards, lifting the woofer from the counterbore. Then, while one person supports the woofer, another can remove both connecting wires from the terminals. Set the woofer aside.

- 5) Inside the cabinet, at the bottom of the HF horn, are the three mounting screws; remove them.
 - 6) The HF horn can now be removed from the cabinet by reaching in and pushing the assembly out; remove both connecting wires from the terminals. Set the HF assembly/horn aside.
 - 7) The (10) screws holding the top cap assembly are now exposed; remove them.
 - 8) Lift the top cap assembly with UHF assembly off the cabinet.
- NOTE:
- a) When replacing the HF horn, to assist the (3) screw holes in lining up properly, one person may have to depress the gasket by pressing the horn assembly down into the cabinet, while the other replaces the screws.
 - b) Remember to observe correct polarity when reattaching all driver wires.

K2 S9800/K2 S9800SE



PARTS LIST K2 S9800

ITEM NO.	DESCRIPTION	QTY.	PART NO.
1.	HF DRIVER HORN	1	337627-003
2.	FRONT BAFFLE	1	338154-001
3.	CROSSOVER NETWORK	1	337978-001
4.	15" WOOFER 1500AL	1	336308-001
5.	HF DRIVER 435BE	1	337361-001
6.	UHF DRIVER 045BE	1	336318-001
7.	FOOT, BASE	4	338067-002
8.	CABINET TOP	1	336921-003
9.	UHF DRIVER HORN	1	337106-002
10.	UHF DRIVER HOUSING	1	337534-003
11.	FRONT GRILLE	1	337854-001
12.	PORT TUBE, METAL	2	335202-002
13.	PORT TUBE, FOAM	2	335203-001
14.	PORT TUBE, PLASTIC, 1.57"	2	335339-003
15.	GRILLE CUP	4	333249-001
16.	DOWEL PIN	8	59266
17.	15" WOOFER GASKET	1	338073-001
18.	HF HORN GASKET	1	337514-001
19.	UHF GASKET, TOP	1	338166-001
20.	UHF GASKET, BOTTOM	1	338165-001
21.	CURVED, CABINET PANEL	1	337916-001
22.	FOOT GASKET	4	338168-001
23.	SCREW, MS, FLPH, 10-32X1.0 BLK, WFR TO ENCL	8	902201-016
24.	SCREW, MS, BHXS, .25-20x1.50, BLK, HF DRVR TO HORN	3	902301-024
25.	SCREW, MS, BHXS, .25-20x1.38, BLK, TOP TO ENCL	6	902301-022
26.	SCREW, MS, BSH, 6-32X.25, SST, TWT HORN TO ANGLE BRKT/TOP	2	909904-004
27.	SCREW, MS, PPH, 8-32x.625", BLK, TWT HOUSING TO TOP	4	900201-010
28.	SCREW, MS, FLPH, .25-20, ZINC, FOOT TO BASE	4	910002-016
29.	SCREW, PB, PPH, #6x.75, BLK, NETWORK TO ENCL	6	903401-012
30.	SHIM	6	338078-001
31.	ANGLE BRACKET FOR UHF DRIVER	2	338167-001
32.	JBL LOGO	1	74714
33.	STAND-OFF, .5"	4	338470-001
34.	NYLON INSERT	6	332259-001
35.	WASHER, FLAT, .25x.5", ZINC, 6X-TOP/ENCL, 3X-DRVR HF/HORN	13	337183-001
36.	XOVER DAMPENING PAD	1	338528-001
37.	BOLT, HEX HD, .25-20x.75, ZINC, ENCL TO HORN	4	47264
38.	GASKET, WASHER, .312ODX.156ID	4	338536-001
39.	STAND-OFF, 2.3"	2	338470-002
40.	SCREW, MS, BSH, 6-32X.38, SST	2	909904-006
41.	FOOT, SLIDE	4	338067-003
PACKING			
42.	OUTER CARTON	1	338313-001
43.	PAD, END, TOP	1	338314-001
44.	PAD, END, BOT	1	338315-001
45.	OWNER'S MANUAL	Download from http://www.jbl.com	
46.	FOOT, SPIKE	4	338067-004
47.	FOOT, BASE, FLOOR	4	338067-005
	WHEEL SPACER, BASE	4	71880
	WHEEL SPACER, SCREW	4	71885

K2 S9800/K2 S9800SE



PARTS LIST K2 S9800SE

ITEM NO.	DESCRIPTION	QTY.	PART NO.
1.	HF DRIVER HORN	1	337627-003
2.	FRONT BAFFLE	1	338154-002
3.	CROSSOVER NETWORK	1	352043-001
4.	15" WOOFER 1500AL	1	336308-001
5.	HF DRIVER 435BE	1	337361-001
6.	UHF DRIVER 045BE	1	336318-001
7.	FOOT, BASE	4	338067-002
8.	CABINET TOP	1	336921-003
9.	UHF DRIVER HORN	1	337106-002
10.	UHF DRIVER HOUSING	1	337534-003
11.	FRONT GRILLE	1	337854-001
12.	PORT TUBE, METAL	2	335202-003
13.	PORT TUBE, FOAM	2	335203-001
14.	PORT TUBE, PLASTIC, 1.57"	2	335339-003
15.	GRILLE CUP	4	333249-001
16.	DOWEL PIN	8	59266
17.	15" WOOFER GASKET	1	338073-001
18.	HF HORN GASKET	1	337514-003
19.	UHF GASKET, TOP	1	338166-001
20.	UHF GASKET, BOTTOM	1	338165-001
21.	CURVED, CABINET PANEL	1	337916-002
22.	FOOT GASKET	4	338168-001
23.	SCREW, MS, FLPH, 10-32X1.0 BLK, WFR TO ENCL	8	804-01110-24
24.	SCREW, MS, BHXS, .25-20x1.50, BLK, HF DRVR TO HORN	3	806-93014-24
25.	SCREW, MS, BHXS, .25-20x1.38, BLK, TOP TO ENCL	6	806-93014-22
26.	SCREW, MS, BSH, 6-32X.25, SST, TWT HORN TO ANGLE BRKT/TOP	2	802-93056-04
27.	SCREW, MS, PPH, 8-32x.625", BLK, TWT HOUSING TO TOP	4	803-41010-10
28.	SCREW, MS, FLPH, .25-20, ZINC, FOOT TO BASE	4	806-01000-16
29.	SCREW, PB, PPH, #6x.75, BLK, NETWORK TO ENCL	6	882-41110-12
30.	SHIM	6	338078-001
31.	ANGLE BRACKET FOR UHF DRIVER	2	338167-001
32.	JBL LOGO	1	352852-001
33.	STAND-OFF, .5"	4	338470-001
34.	NYLON INSERT	6	332259-001
35.	WASHER, FLAT, .25x.5", ZINC, 6X-TOP/ENCL, 3X-DRVR HF/HORN	13	337183-001
36.	XOVER DAMPENING PAD	1	338528-001
37.	BOLT, HEX HD, .25-20x.75, ZINC, ENCL TO HORN	4	854-00000-12
38.	GASKET, WASHER, .312ODX.156ID	4	338536-001
39.	STAND-OFF, 2.3"	2	338470-002
40.	SCREW, MS, BSH, 6-32X.38, SST	2	802-93056-06
41.	FOOT, SLIDE	4	338067-003
PACKING			
42.	OUTER CARTON	1	338313-001
43.	PAD, END, TOP	1	339596-001
44.	PAD, END, BOT	1	339597-001
45.	OWNER'S MANUAL	Download from http://www.jbl.com	
46.	FOOT, SPIKE	4	338067-004
47.	FOOT, BASE, FLOOR	4	338067-005
	WHEEL SPACER, BASE	4	71880
	WHEEL SPACER, SCREW	4	71885

K2 S9800/K2 S9800SE